

2017 Interplanetary Small Satellite Conf.

San Jose, CA, USA; 1-2 May 2017

MarCO

Mars Cube One

Telecom System Design

M. Michael Kobayashi

Jet Propulsion Laboratory at
the California Institute of Technology

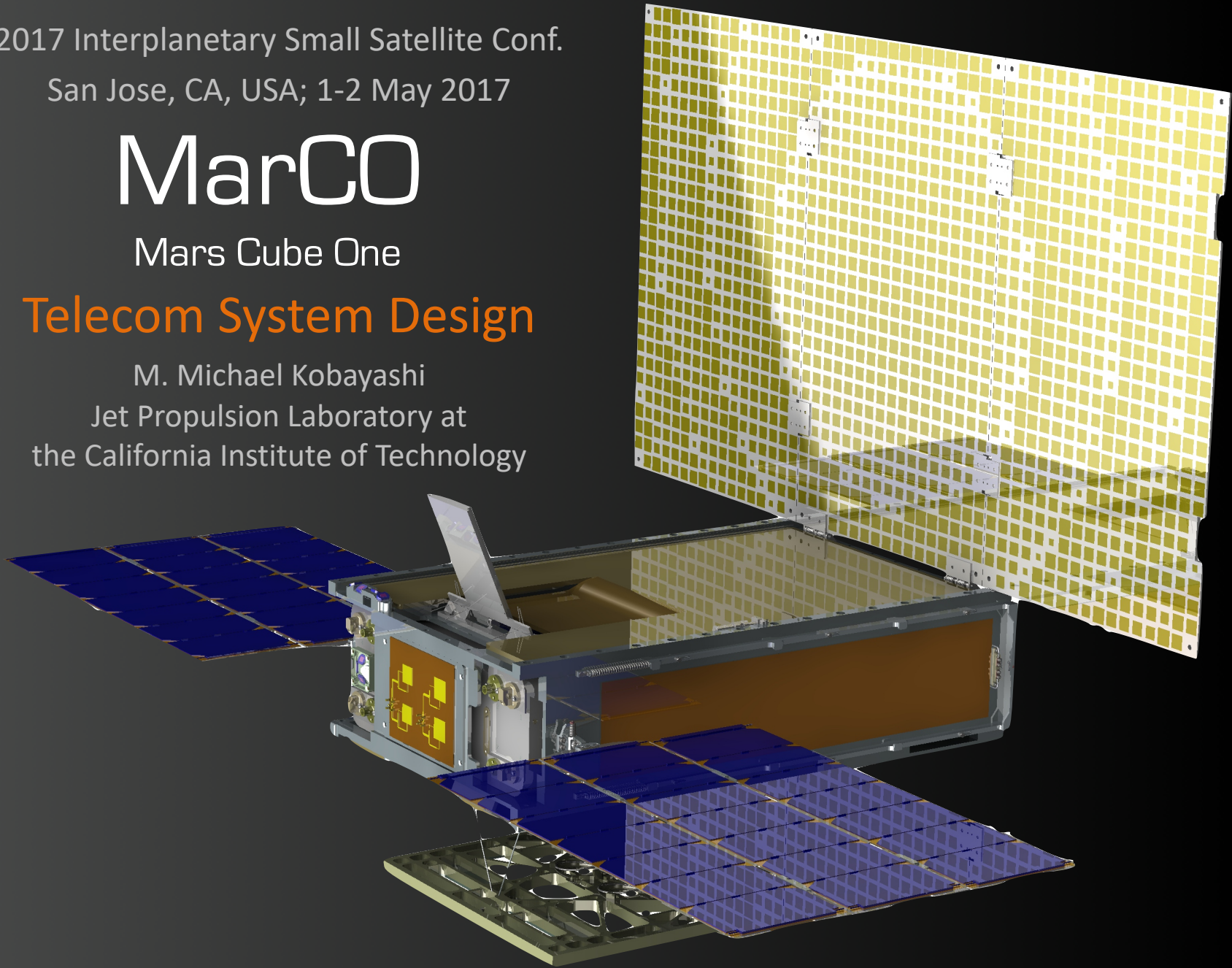

- ✧ MarCO Concept of Operations and Overview
- ✧ Challenging Requirements for EDL Telecom
- ✧ Telecom System Elements
- ✧ MarCO CubeSat Configuration
- ✧ Digital Bent-Pipe Architecture
- ✧ UHF Receiver Design
- ✧ Link margins (DTE and InSight)
- ✧ Major Telecom Test Campaigns
- ✧ Conclusions

Concept of Operations

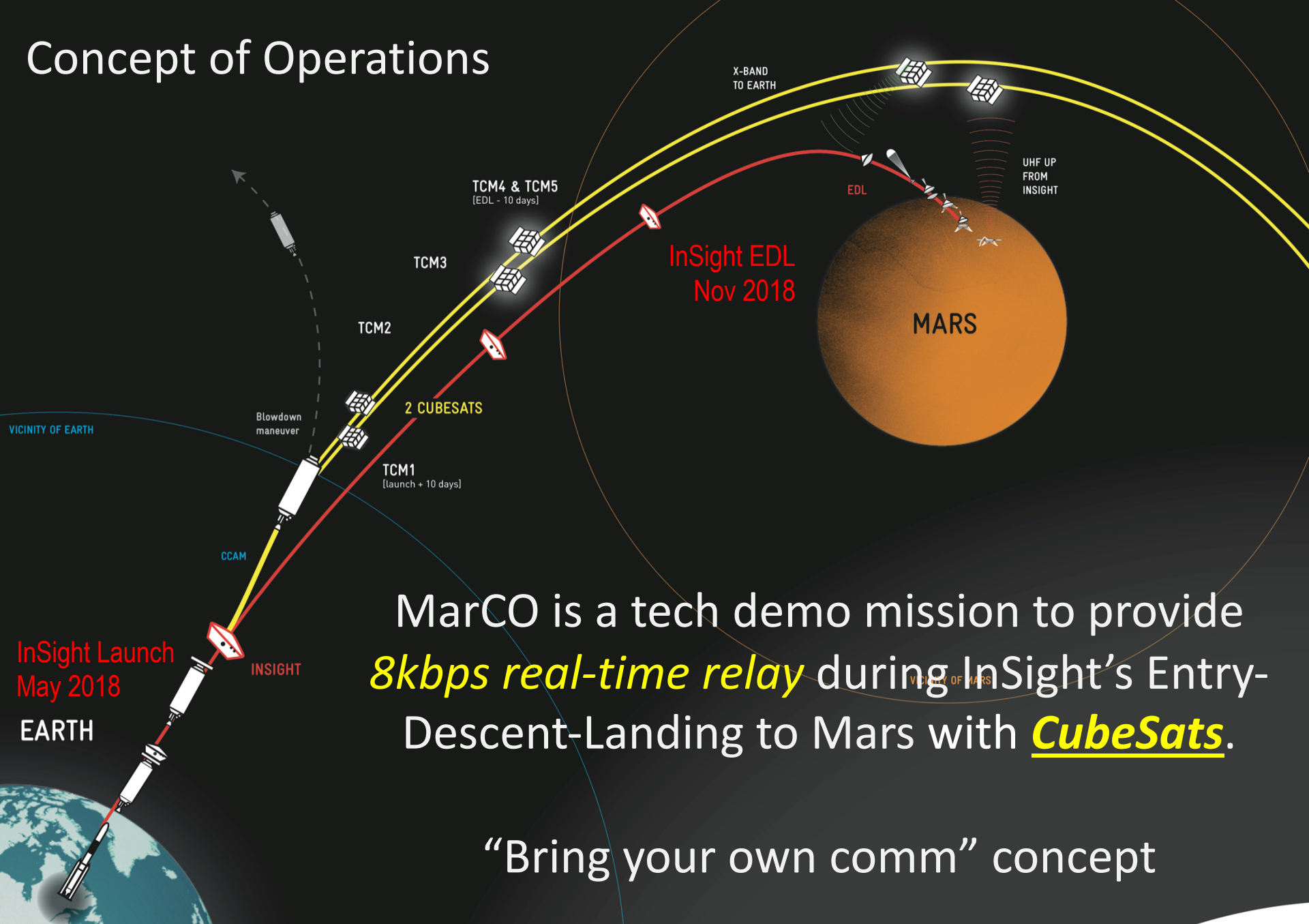

MarCO is a tech demo mission to provide **8kbps real-time relay** during InSight's Entry-Descent-Landing to Mars with **CubeSats**.

“Bring your own comm” concept

Challenging Requirements for EDL Telecom

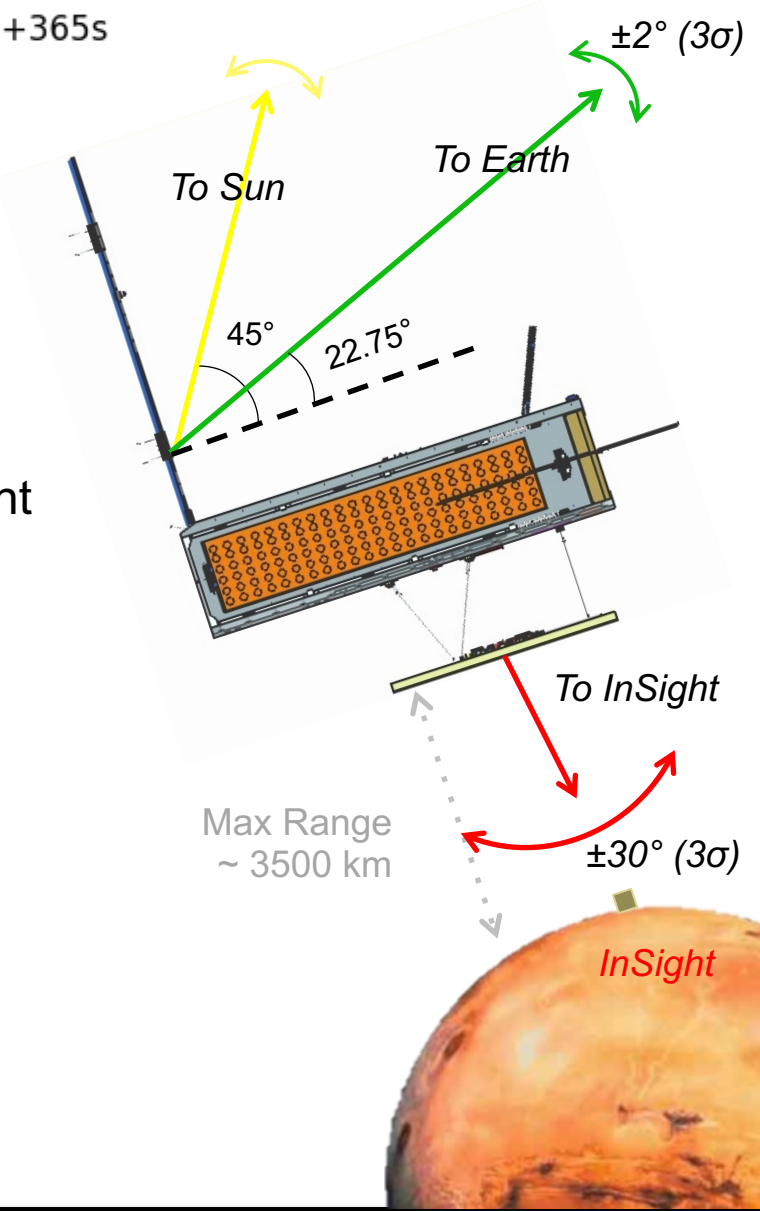
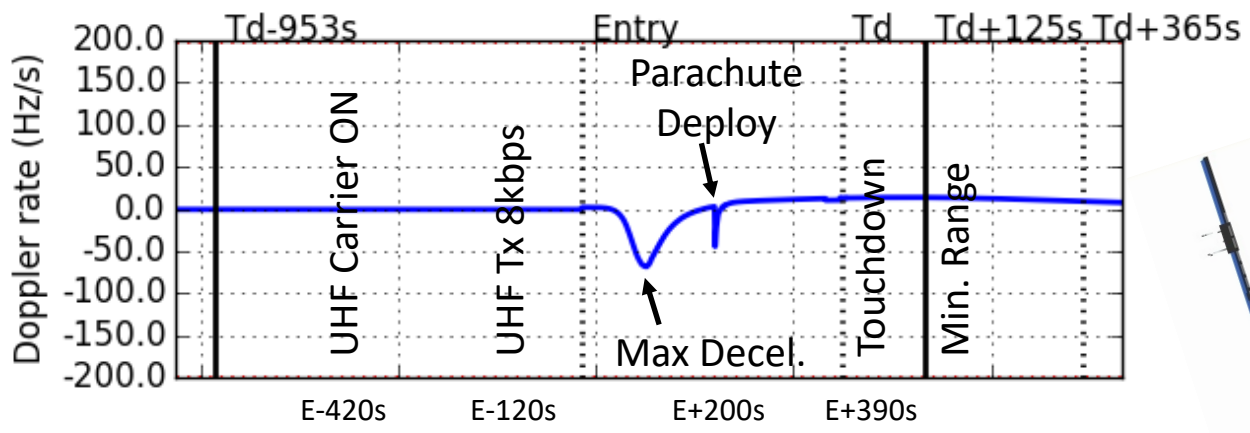

- ❖ High spacecraft dynamics b/w MarCO and InSight
 - $\pm 20\text{kHz}$ Doppler shift with max 200 Hz/s rate
- ❖ Direct-to-Earth at 8kbps to 70m DSN station
 - X-band transmit EIRP of 59 dBm over $\pm 2^\circ$
 - Max topocentric range: 1.07 AU (160 Mkm)
- ❖ Large UHF antenna angle of observation
 - UHF 0 dBi gain over $\pm 30^\circ$
 - Max slant range: 3500 km
- ❖ Bent-pipe Relay Transmission
 - 22 minutes of EDL data recording capacity
 - Capability for post-EDL re-transmission

Telecom System Elements

- ✧ Greatly upgraded transponder designs based on Iris V1 from INSPIRE
- ✧ Novel X-band reflectarray design for DTE communications
- ✧ Newly developed UHF receiver
- ✧ Deployable UHF loop antenna

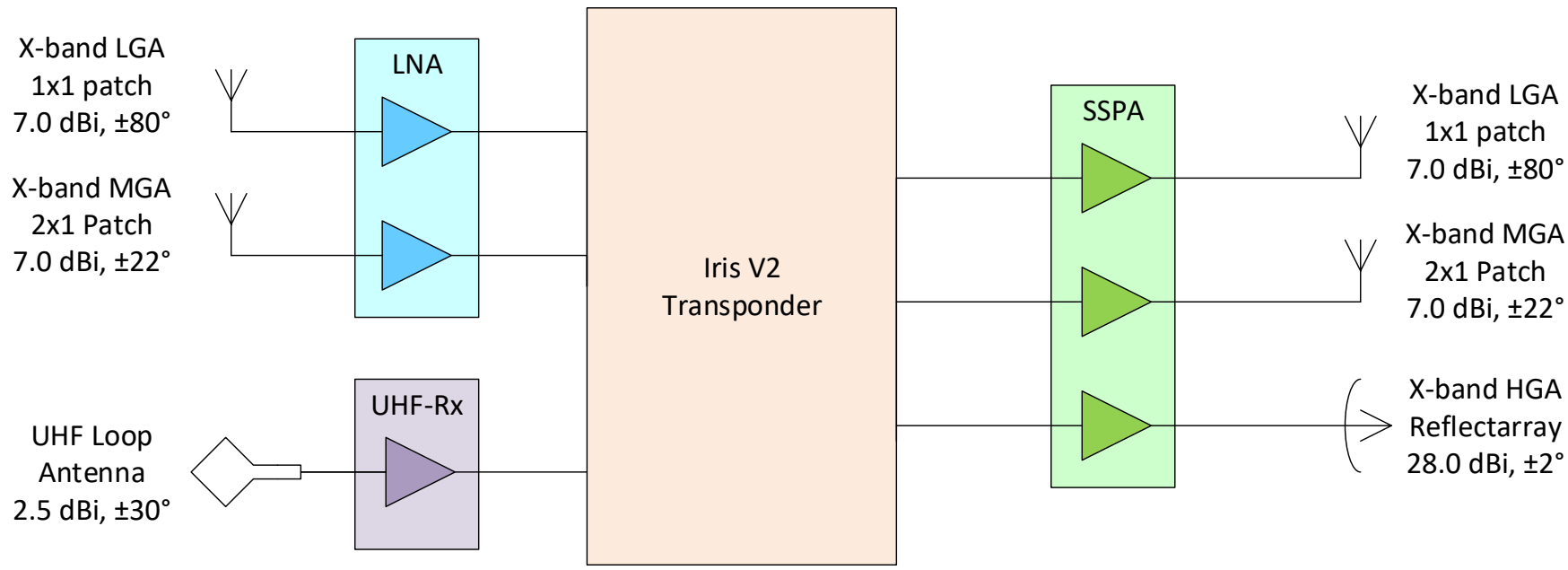

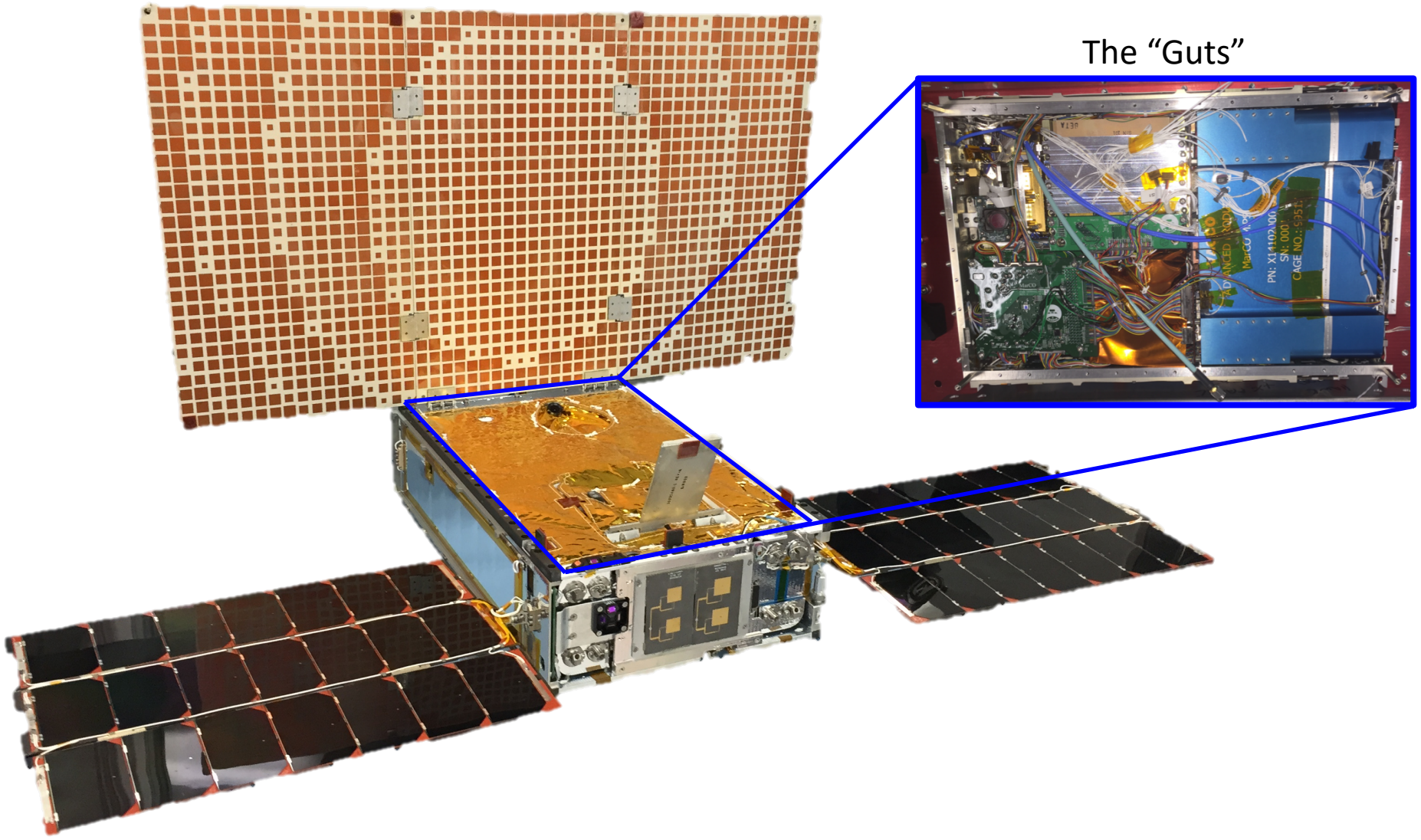

The "Guts"

MarCO CubeSat

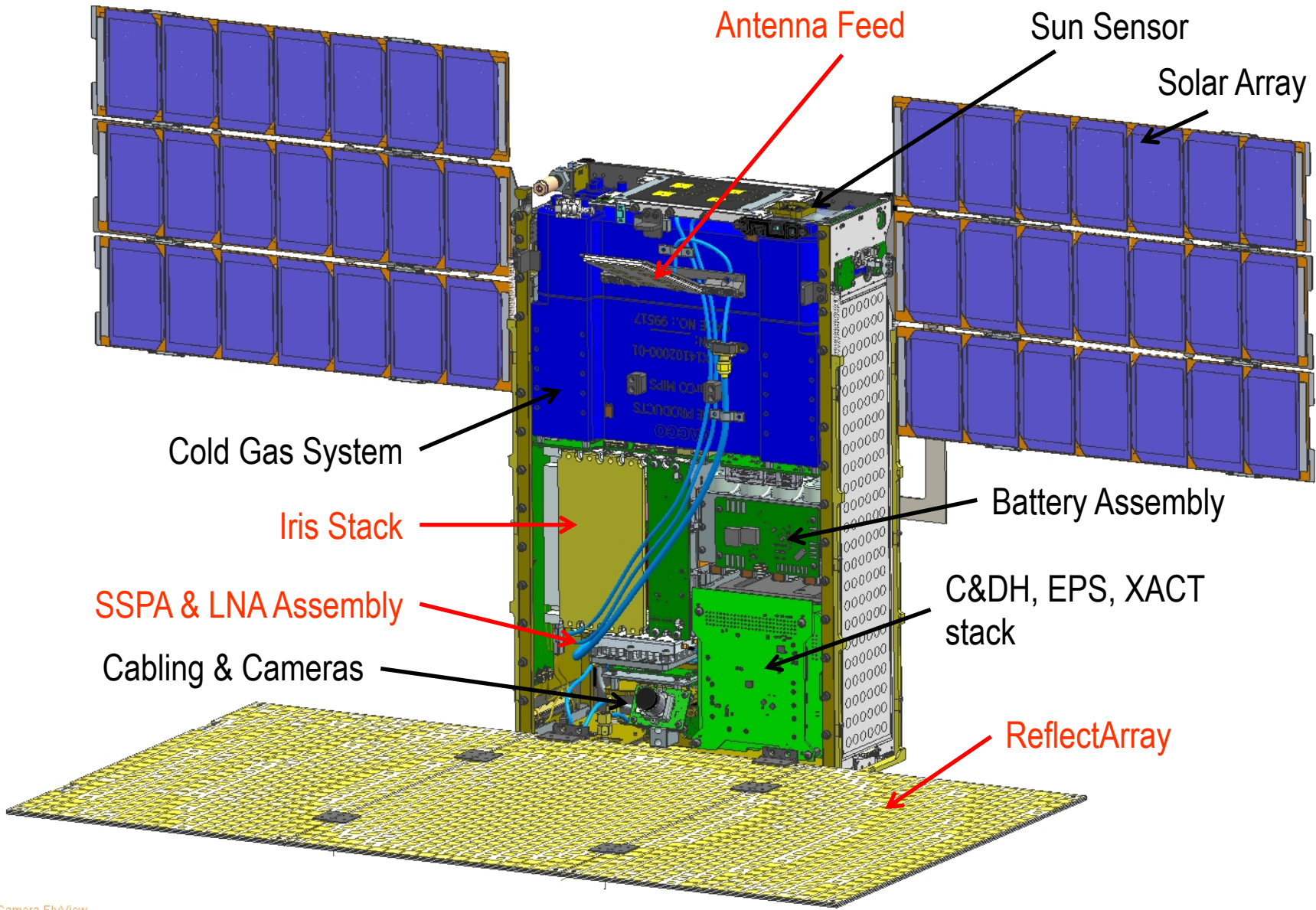

V. Campos, ESA/flow

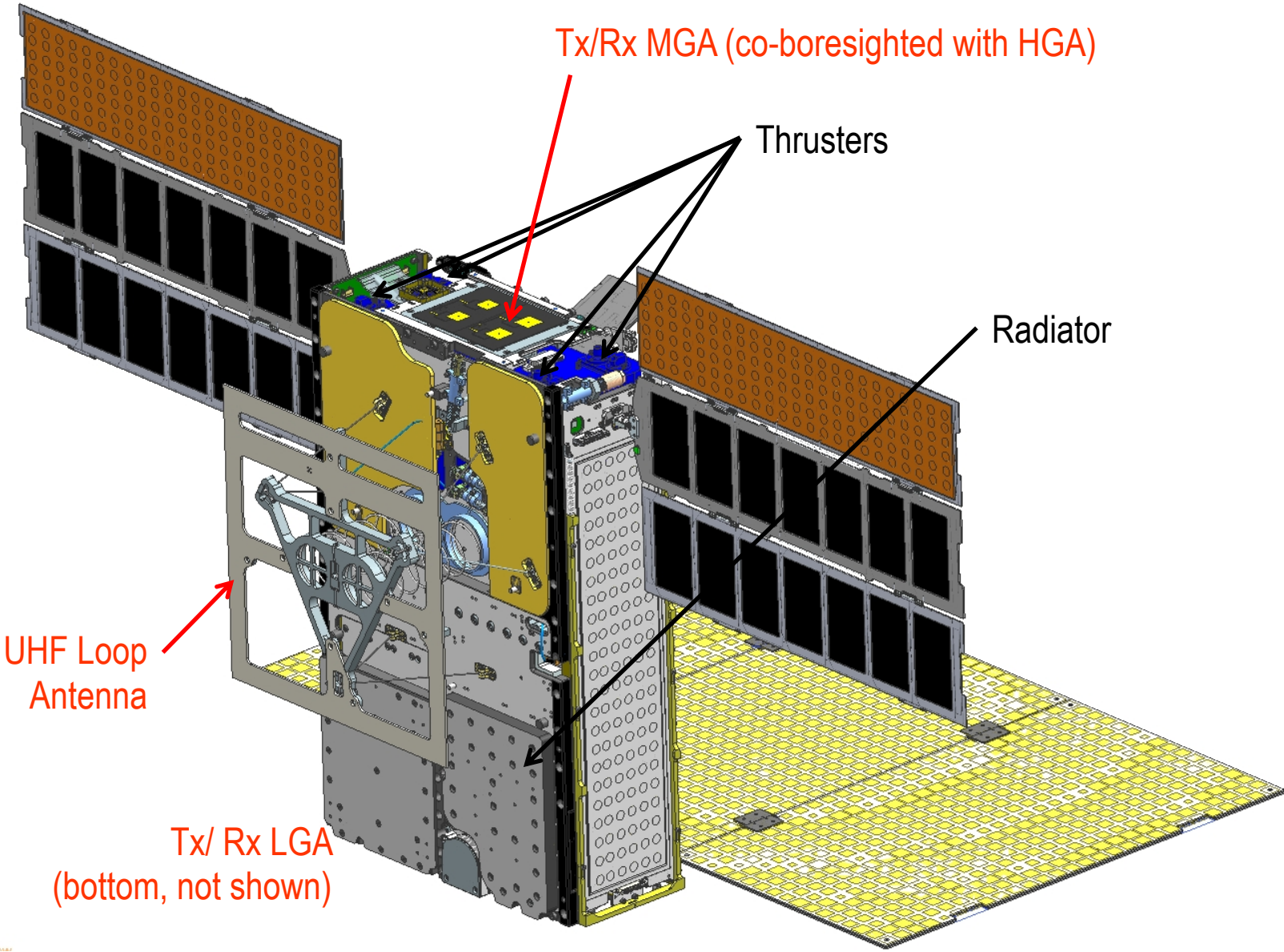

Antenna Designs

- ✧ R. E. Hodges, N. Chahat, D. J. Hoppe and J. D. Vacchione, "A Deployable High-Gain Antenna Bound for Mars: Developing a new folded-panel reflectarray for the first CubeSat mission to Mars.," in *IEEE Antennas and Propagation Magazine*, vol. 59, no. 2, pp. 39-49, April 2017.
- ✧ N. Chahat and R. E. Hodges, "Enabling deep space CubeSat missions: Telecommunication challenge", MARS CubeSat/NanoSat Workshop, Pasadena, CA, Nov 2014.

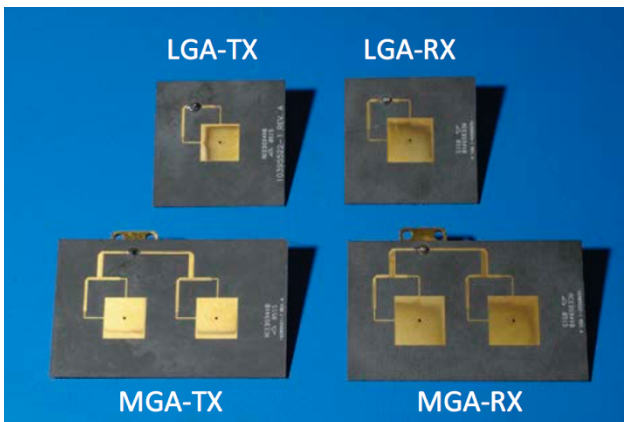

X-band Patch Antennas

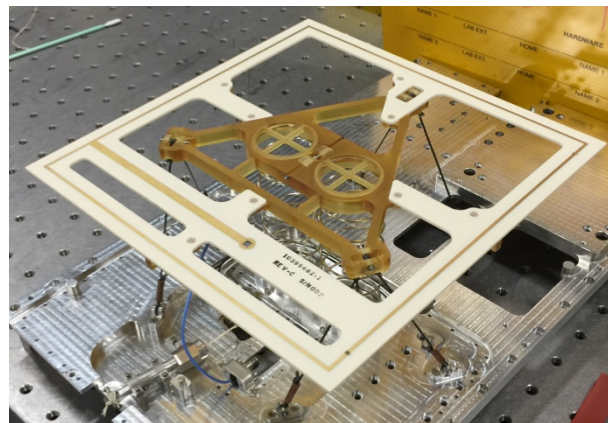

UHF Loop Antenna

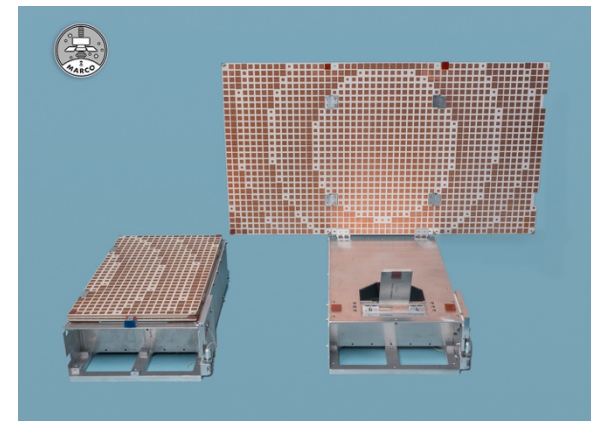

X-band HGA Reflectarray

Digital Bent-Pipe Architecture

- ✧ Digital bent-pipe scheme (non-analog), performed directly by the radio
 - InSight transmits in raw mode, incompatible with DSN station processing
 - MarCO flight system uses MSP430-based CDH running at 12 MHz with only 8kByte RAM
 - MarCO requires a re-transmission mode for post-EDL
- ✧ Relay is done with CDH out-of-the-loop to minimize data latency
- ✧ Iris Digital Processor Board upgrades
 - Embedded Leon-3FT softcore processor for EDL data management
 - AOS Framer (typically on CDH unit) implemented in software
 - Hardware memory elements (2MB SRAM, FLASH)
 - Firmware Viterbi decoder for InSight EDL data (convolutional coded)

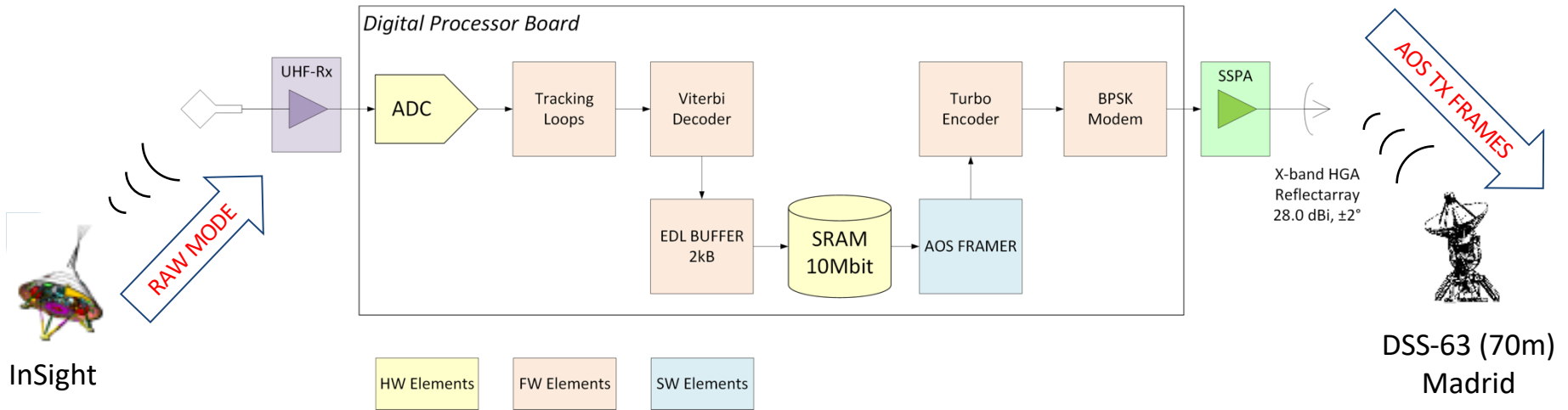

UHF Receiver Design

- ✧ Shares IF amplification/filter stage with X-band Rx
 - Reduces size and volume
 - Only one ADC required on digital board
- ✧ Traditional superheterodyne receiver with one downconverter stage
- ✧ General Requirements:
 - Receive frequency range: 390 – 405 MHz
 - Downconvert to 112.5 MHz
 - Noise figure < 5 dB

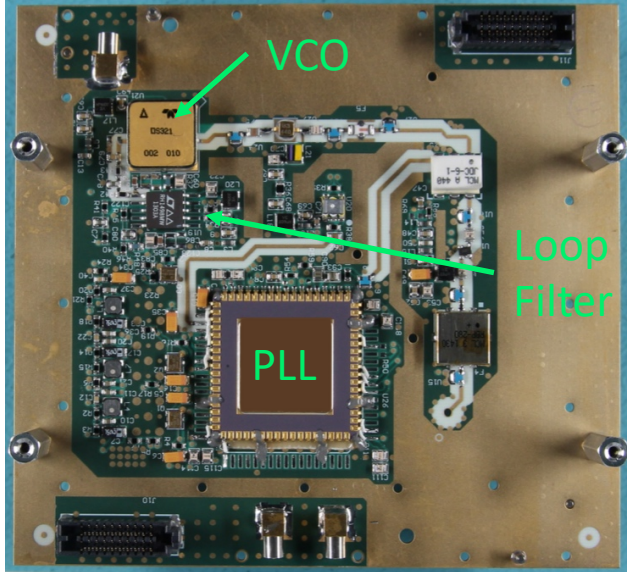
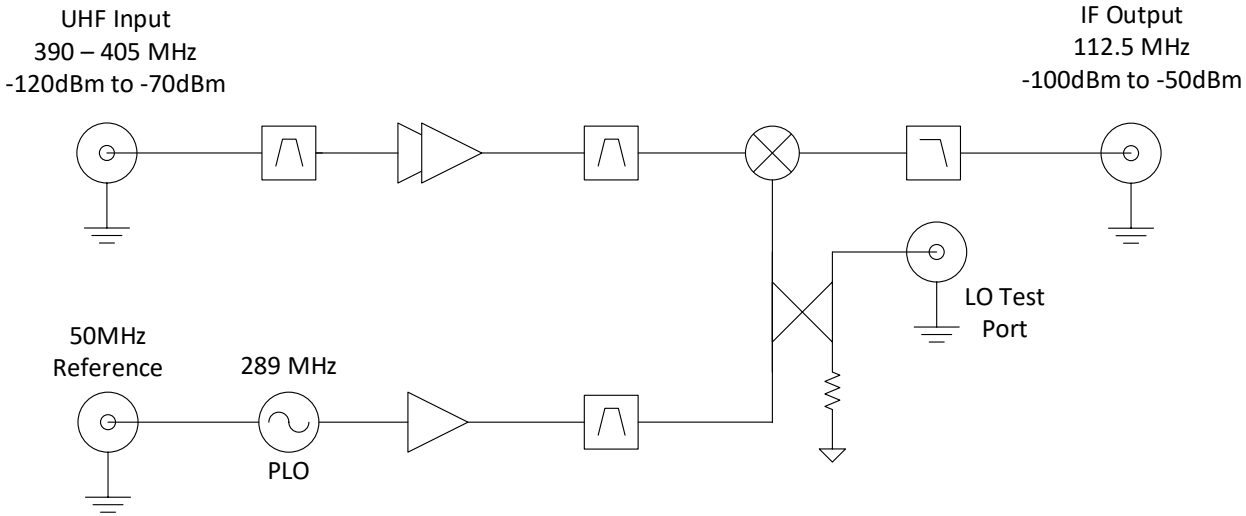
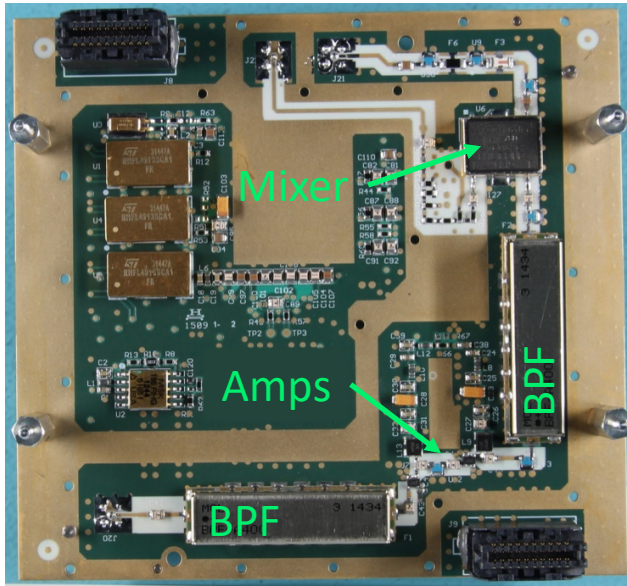



X-band Link Margins at EDL

Uplink Parameter		Units	Value
Tx Station	Transmitter Power	kW	20.0
	Passive/Pointing Losses	dB	-0.75
	DSS-54, 34m Antenna Gain	dBi	67.0
	EIRP	dBm	139.25
Path	Atmospheric Attenuation	dB	-0.20
	Free Space Path Loss	dB	-273.6
MarCO Receiver	Receiving Antenna Gain (MGA)	dBi	8.9
	Antenna/Passive Losses	dB	-3.3
	Total Received Power (Pt)	dBm	-129.0
	Rcvr Noise Figure	dB	3.5
	Noise Spectral Density (No)	dBm/Hz	-172.0
	Received Pt/No	dB-Hz	43.0
Data Channel	Data Supp. (mod index = 1.5r)	dB	-2.1
	Data Rate (62.5 bps)	dB-bps	18.0
	System Losses	dB	-3.0
	Th. Eb/No (uncoded, BER=1e-5)	dB	9.6
	Req'd Pt/No	dB-Hz	32.7
Uplink Margin		dB	10.3

Downlink Parameter		Units	Value
MarCO Tx.	Transmitter Power	W	4.6
	Passive/Pointing Losses	dB	-4.2
	Transmit Antenna Gain (HGA)	dBi	28.8
	EIRP	dBm	61.2
Path	Atmospheric Attenuation	dB	-0.15
	Free Space Path Loss	dB	-275.0
Receiving Station	DSS-63, 70m Antenna Gain	dBi	74.3
	Antenna/Passive Losses	dB	-0.3
	Total Received Power (Pt)	dBm	-139.8
	System Noise Temp	K	25.5
	Noise Spectral Density (No)	dBm/Hz	-184.5
	Received Pt/No	dB-Hz	44.7
Data Channel	Data Supp. (mod index = 77°)	dB	-0.23
	Data Rate (8000 bps)	dB-bps	39.0
	System Losses	dB	-0.8
	Th. Eb/No (Turbo-1/6, FER=1e-4)	dB	-0.1
	Req'd Pt/No	dB-Hz	40.0
Downlink Margin		dB	4.7

UHF Link Margins at EDL

Uplink Parameter		Units	Value
InSight Tx.	Transmitter Power	W	14.8
	Passive/Pointing Losses	dB	-2.0
	InSight Antenna Gain	dBi	-1.0
	EIRP	dBm	38.7
Path	Atmospheric Attenuation	dB	0
	Free Space Path Loss	dB	-154.9
MarCO Receiver	Receiving Antenna Gain (UHF)	dBi	2.9
	Antenna/Passive Losses	dB	-3.8
	Total Received Power (Pt)	dBm	-117.1
	Rcvr Noise Figure	dB	3.6
	Noise Spectral Density (No)	dBm/Hz	-170.9
	Received Pt/No	dB-Hz	53.8
Data Channel	Data Supp. (mod index = 60°)	dB	-1.25
	Data Rate (8000 bps)	dB-bps	39.0
	System Losses + EMI	dB	-7.2
	Th. Eb/No (RS, BER=1e-3)	dB	3.5
	Req'd Pt/No	dB-Hz	51.0
InSight-MarCO Link Margin		dB	2.8

InSight antennas may have up to 5dBi gain on boresight.
Antennas will be switching during EDL = causes dropouts

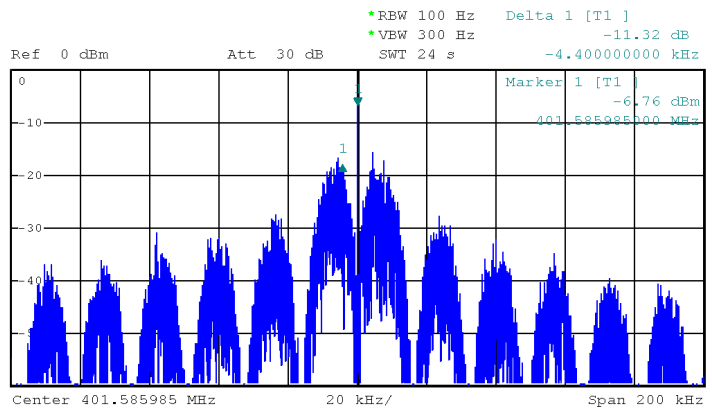
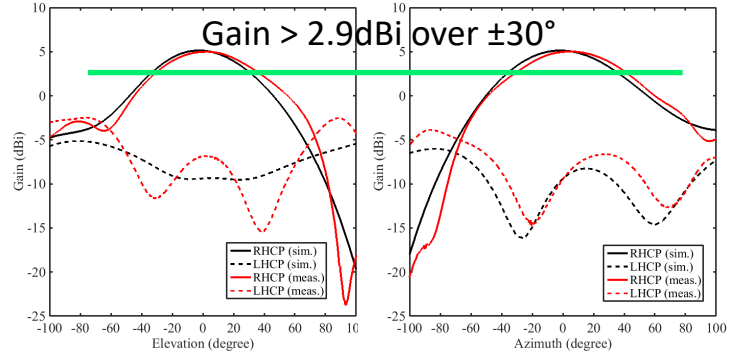
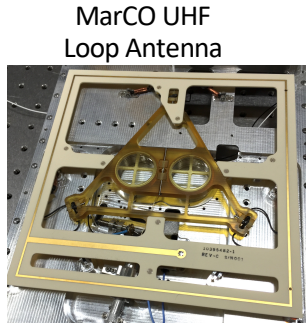
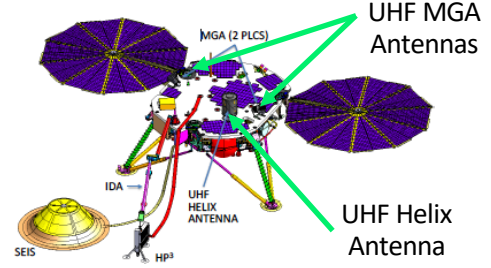
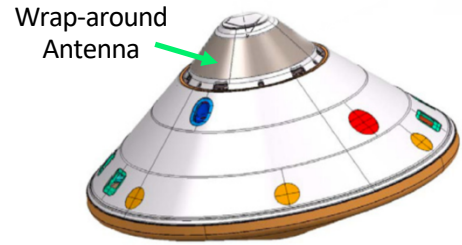

- InSight Spectrum**
- 8kbps
 - Manchester
 - RS(252,220)
 - Conv (k=7, r=1/2)
 - Residual Carrier
 - Mod index 60°

Major Telecom Test Campaigns

- ✧ Iris Transponder ambient tests
- ✧ Downlink tests against TDL Block-V Receiver
- ✧ UHF channel simulator tests
- ✧ InSight-MarCO compatibility tests at Lockheed Martin
- ✧ DTF-21 DSN compatibility test
- ✧ EMI/EMC “plugs-out” self-compatibility test

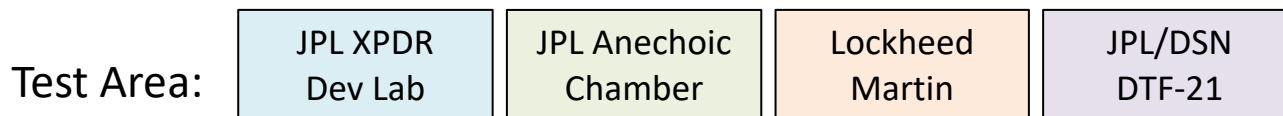
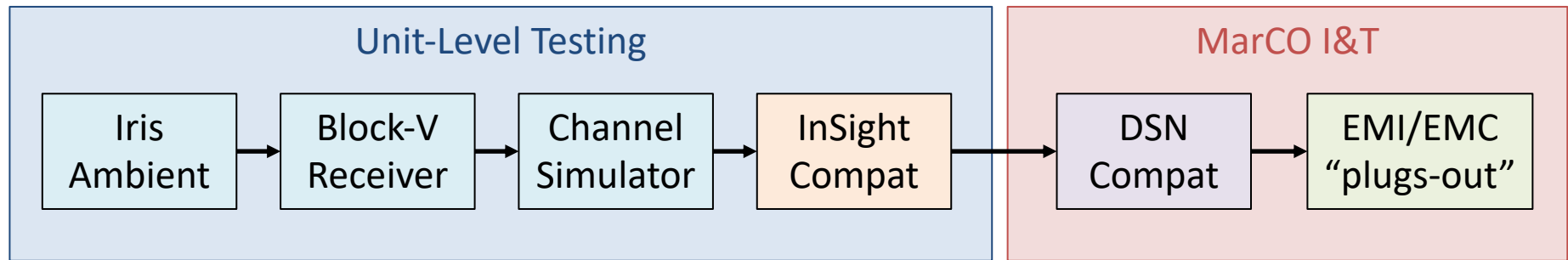

Iris Ambient Tests

- ✧ Power consumption and in-rush
- ✧ LNA noise figure
- ✧ SSPA RF Output Power
- ✧ Downlink tests at 62.5, 1k, 8k bps
- ✧ Uplink tests at 62.5 and 1kbps
- ✧ Uplink threshold and bit-error rate
- ✧ UHF return link at 8kbps
- ✧ UHF return link threshold/BER
- ✧ Navigational test (Ranging, DDOR)

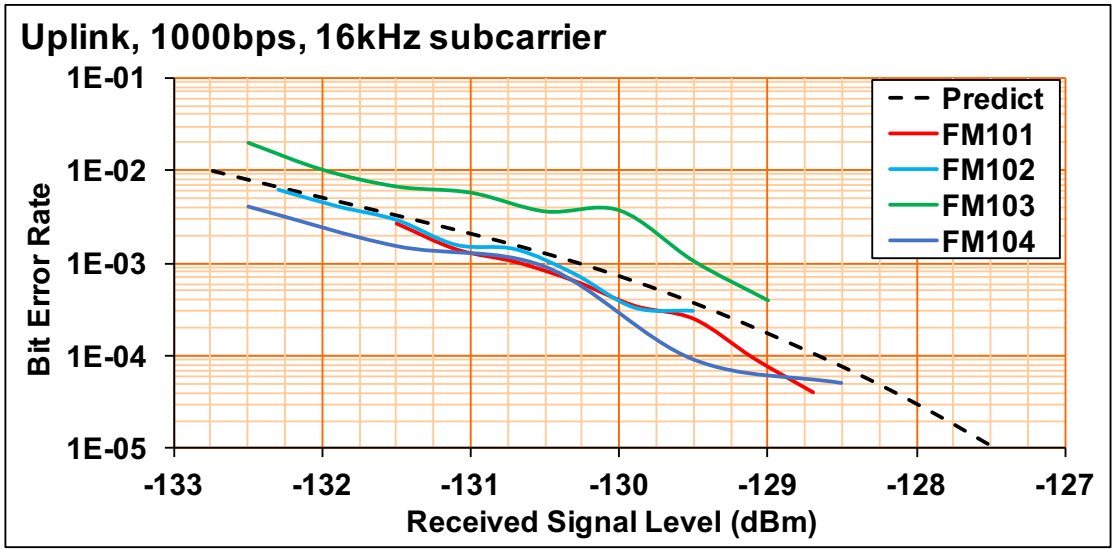
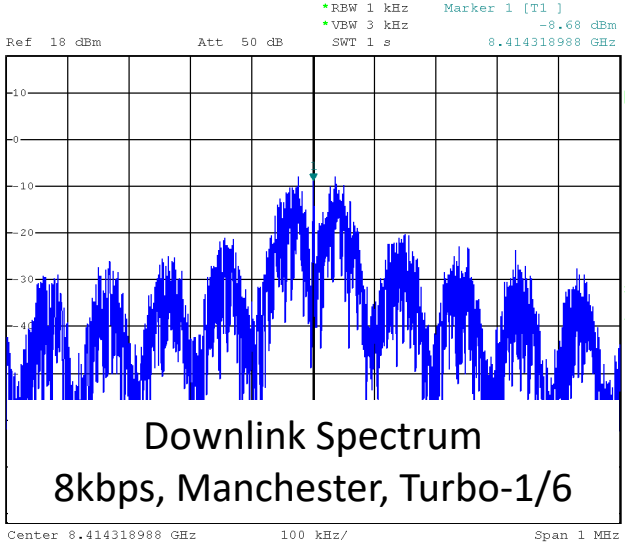
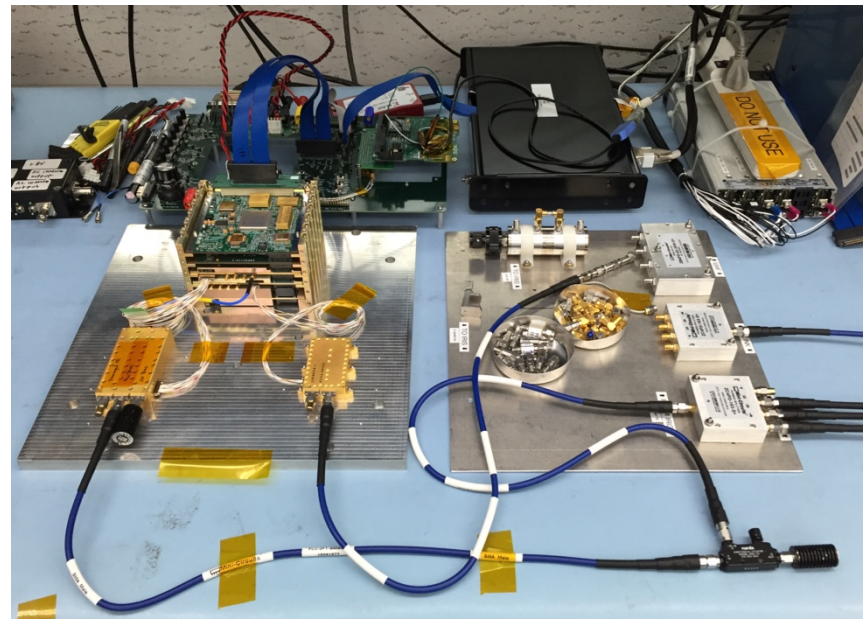

Block-V Receiver Tests

- ✧ 5th generation DSN receivers currently used at all DSN complexes
- ✧ Supports all telemetry reception and decoding described in DSN 810-206B
- ✧ Early compatibility tests before formal DSN compatibility tests
 - Verifies carrier performance for acquisition and tracking
 - Verifies telemetry encoding (Turbo-1/6) integrity
 - Measure expected performance loss with FER curves

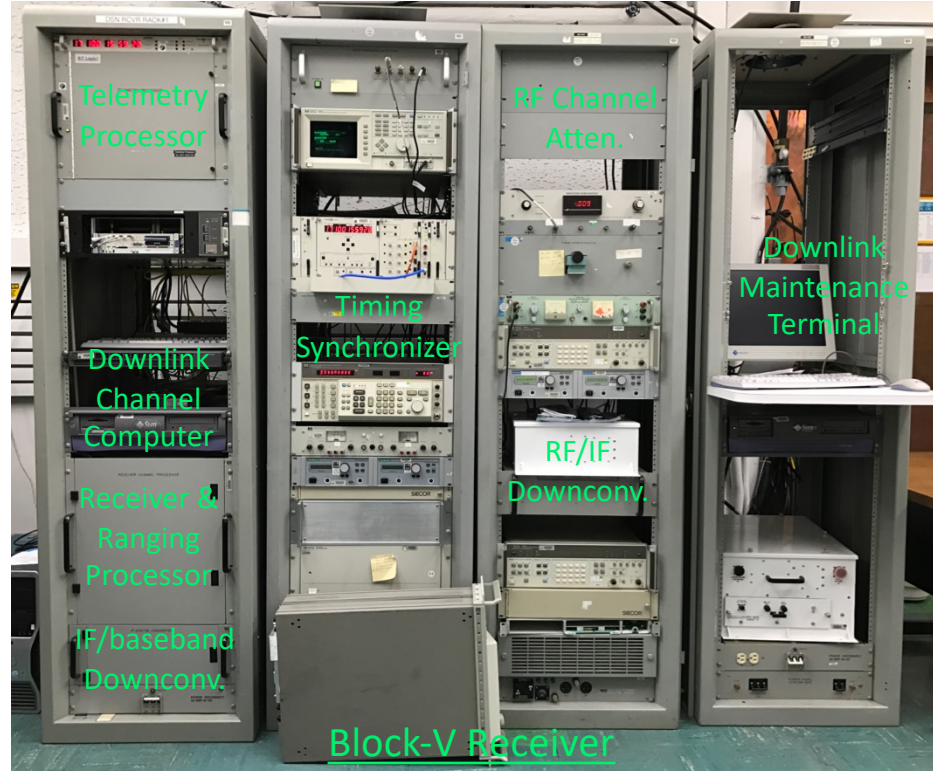
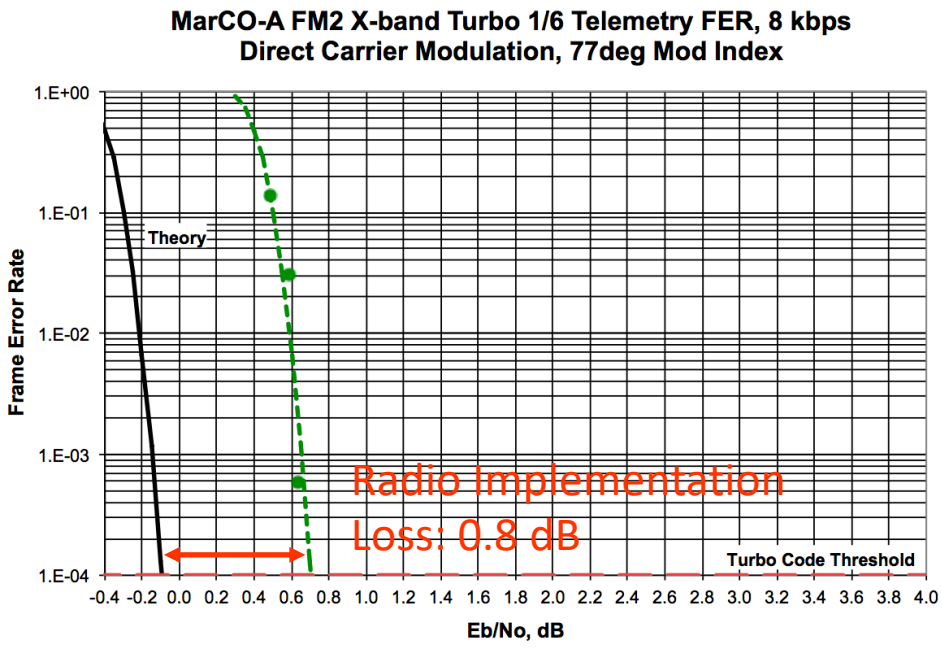

UHF Channel Simulator Tests

✧ Flight-like end-to-end bent-pipe configuration test with Channel Simulator

- Provides Doppler profiles (expected and worst-case predicts)
- Injects signal drop-outs to stress test Iris receiver

Test Case Description	Doppler	Dropouts	Duration
Basic, short	None	None	5 min
Basic, full	None	None	24 min
Expected Doppler	Flight Profile	None	24 min
Worst-Case Doppler	$\pm 20\text{kHz}$, 200Hz/s	None	24 min
Expected Doppler + Dropout	Flight Profile	Yes	24 min
Worst-case Doppler + Dropout	$\pm 20\text{kHz}$, 200Hz/s	Yes	24 min
Flight-like	Flight Profile	Yes	24 min
Retransmit	None	None	N/A



InSight Tx equivalent

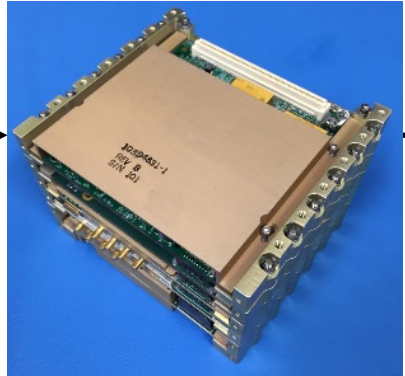
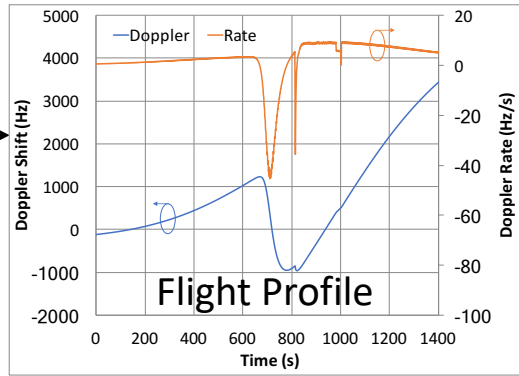

InSight-MarCO UHF Compatibility Tests

Field test conducted at Lockheed Martin (Nov 11-12, 2015)

Test Relay Partner	Description	BER	Notes
InSight Flight System UHF Transmitter	10 min transmission 2 signal dropouts	6.26e-5	Symbol sync errors during dropout transitions appear as bit errors in final transmission.
		4.50e-1	
		8.47e-6	
InSight STL (mostly EM HW)	10 min transmission No signal dropouts	0	No bit errors.
	1 min transmission 1 signal dropout 10 min transmission	0	No bit errors.
		1.66e-6	Errors in first/last frames. Symbol sync errors during dropout transitions.



InSight STL Tx

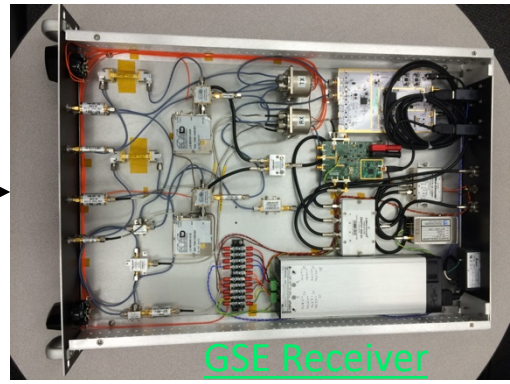
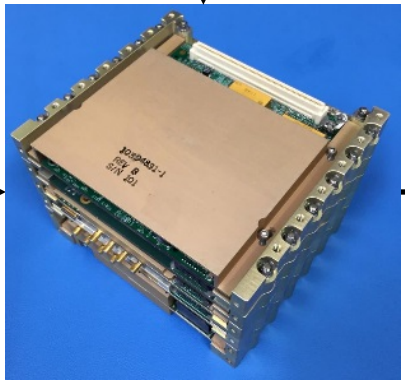

DSN DTF-21 Compatibility Tests

- ✧ Compatibility tests required by the DSN to demonstrate RF interoperability
- ✧ DTF-21 provides an environment that represents an actual DSN Signal Processing Center for testing.

Compatibility Test	MarCO-A	MarCO-B
Uplink Receiver Threshold and AGC Calibration	Carrier Only: -140 dBm Carrier/CMD/RNG: -132 dBm	Carrier Only: -140 dBm Carrier/CMD/RNG: -132 dBm
Uplink Receiver Acquisition and Tracking	100 Hz/s threshold: -134 dBm 200 Hz/s threshold: -131 dBm	100 Hz/s threshold: -134 dBm 200 Hz/s threshold: -132 dBm
Uplink Receiver Tracking Range	Pass: ± 20 kHz	Pass: ± 20 kHz
Downlink Transmitter RF Output Power	+36.0 dBm (3.98 W)	+34.0 dBm (2.51 W)
Downlink RF Spectrum Analysis	Captured 62.5, 1k, 8k bps	Captured 62.5, 1k, 8k bps
Downlink Receiver Threshold	5 Hz LBW: -159 dBm 20 Hz LBW: -152 dBm	5 Hz LBW: -155 dBm 20 Hz LBW: -150 dBm
Command Performance	1kbps threshold: -132 dBm	1kbps threshold: -132 dBm
Telemetry Performance	Symbol Rate: 48,076.9 sps 8kbps Pt/No: 42.7 dB-Hz	Symbol Rate: 48,076.9 sps 8kbps Pt/No: 42.8 dB-Hz
Range Delay and Polarity	Range Delay: 10314 ns	Range Delay: 10797 ns

EMI/EMC Self-Compatibility Tests

- ✧ Instead of traditional subsystem EMI/EMC tests, MarCO elicited a flight-system level self-compatibility test to reduce schedule.
- ✧ Various configurations were tested to observe the effect on the UHF receive threshold as subsystems were turned on/off.
- ✧ Results were used to update InSight-MarCO UHF link budget.

Plugs Config	CDH /EPS	XACT	Cam	UHF Rx Thresh	Viterbi Thresh
In	ON	OFF	OFF	-128	-118
In	ON	ON; 3500rpm	OFF	-127	-118
In	ON	ON; 3500rpm	ON	-124	-117
Out	ON	ON; 3500rpm	OFF	-122	-117
Out	ON	ON; 3500rpm	ON	-121	-116

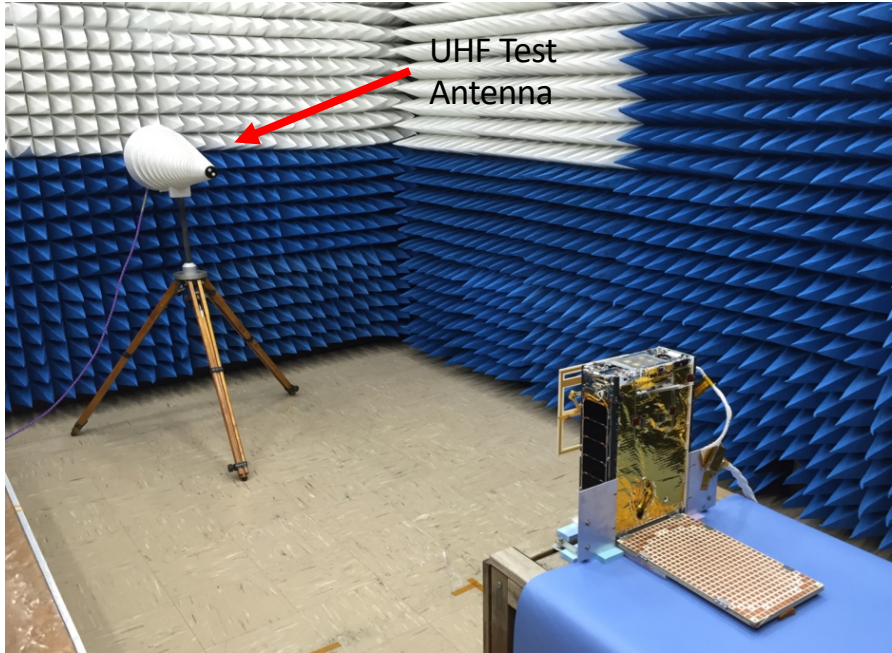

Current MarCO Status

Mar'18: Deliver FM1 & FM2 to Launch Vehicle

Stowed Configuration

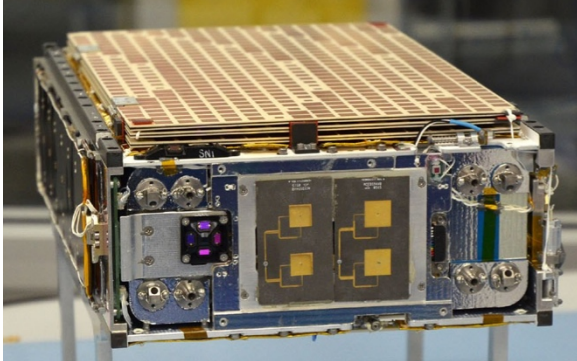
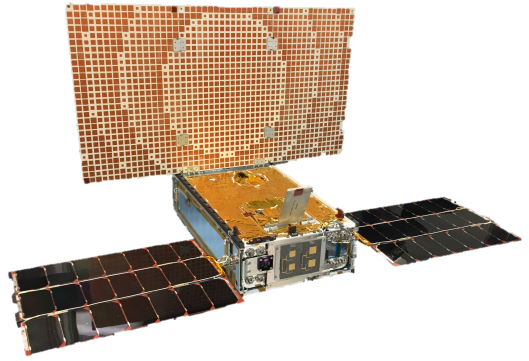

Apr'18: Integrate to InSight Launch Vehicle

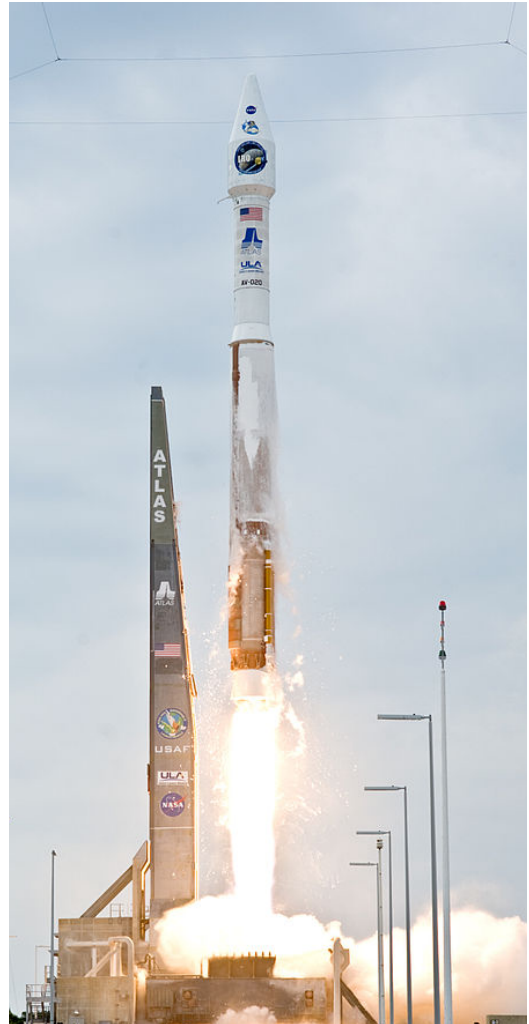
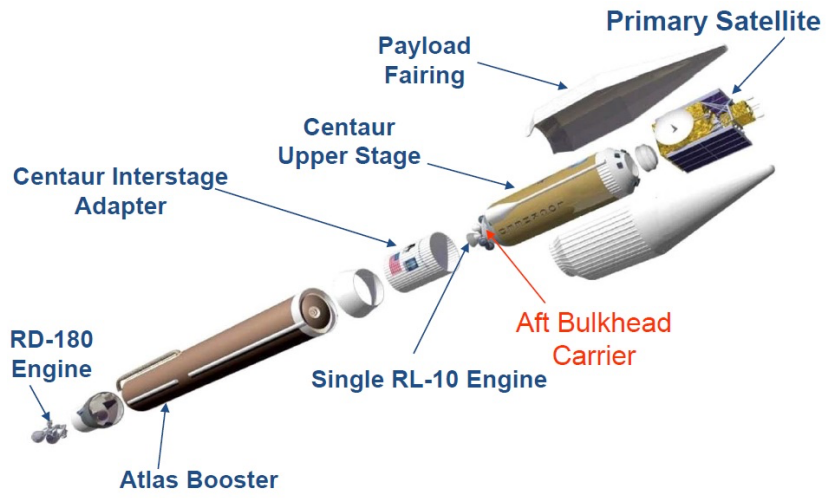

InSight Launch Window:
May 2018

Conclusions

*MarCO mission will demonstrate **small spacecraft capabilities** and **new instruments** for **future** (larger) planetary missions.*

Go new places



Increase the frequency



Validate instrument and S/C technologies

MarCO Telecom Team (and those who helped!)

Alex Hackett, Amy Smith, Anusha Yarlagadda, Brian Custodero, Bob Dengler, Charley Dunn, Danh Nguyen, Daniel Hoppe, Dave Bell, Deborah Drake, Don Heyer, Dorothy Lewis, Douglas Wang, Edgar Satorius, Emmanuel Decrossas, Eric Archer, Fernando Aguirre, Gerald Walsh, Hadi Mojaradi, Heather Owen, Igor Kuperman, Jim Lux, Jimmy Chen, Joel Steinkraus, John Baker, John Leichty, Joseph Vacchione, Kameron Larsen, Kris Angkasa, Larry Epp, Mary Soria, Matthew Chase, Michael Ciminera, Michael Kilzer, Nacer Chahat, Peter Illott, Quintin Ng, Ray Quintero, Ricardo Mendoza, Richard Hodges, Richard Rebele, Robert Cong, Ronald Morgan, Salman Haque, Samuel Zingales, Sarah Holmes, Steve Waldherr, Tatyana Dobreva, Tuyen Ly

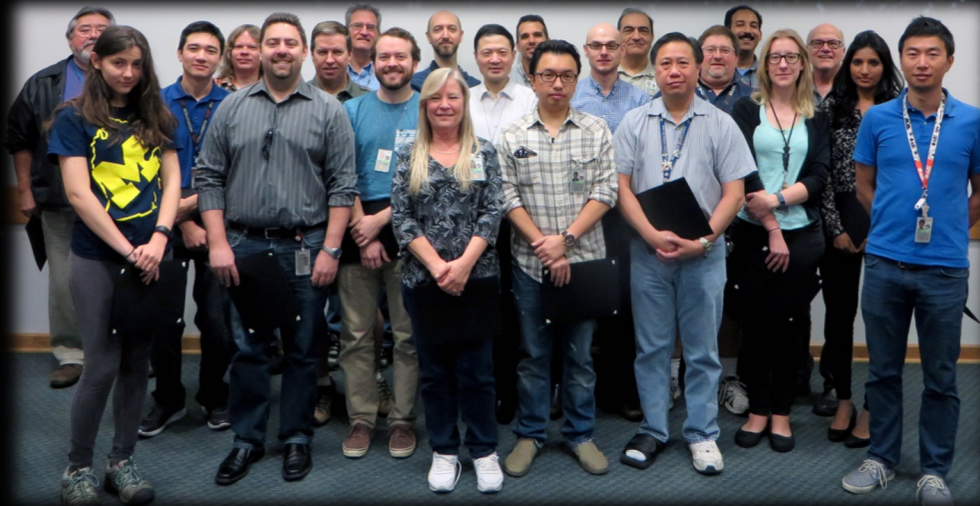



Jet Propulsion Laboratory
California Institute of Technology

jpl.nasa.gov